

Outdoor High-Res Weather-Proof Day & Night IR Camera

IR2536H



Key Features

- 1/3" SONY ExView HAD CCD Image Sensor
- SONY Digital Signal Processing (DSP) Chip set
- 3.6/ 6.0 mm board lens , 520 High TV Lines
- 36 nos. of 850nm IR LED, 25 meters coverage (night)
- Build in CDS Delay Chip set for IR LED Sensor
- IP67 IEC Weather Proof standard
- Made in Taiwan



Specifications

Brand	TANDÉR
Model	IR2536H
Image Pick-up Devise	1/3 " SONY ExView HAD CCD
Signal System	PAL
Total /Effective Pixels	752(H)x 582(V) 480K
Scanning System	2 : 1 Interlace
Lens	3.6mm / 6.0mm Board Lens
Scanning Frequency	50Hz(VD), 15.625Hz(H), 50Hz(V)
Resolution	520TV lines
Video Output	CVBS : 1.0Vp-p / 75 composite BNC Connector
S / N Ratio	More than 48dB (AGC Off)
IR LED	36 nos. of 850nm IR LED, 25 meters coverage (night)
Min. Illumination	0.1 Lux (F : 1.2) , 0 Lux (IR LED On)
Sync. System	Internal
Signal Process	Digital Signal Processing
Back Light Compensation	Built-in
Gain Control	Auto
Electronic Shutter Speed	Auto / (1/50 ~ 1/100,000)
White Balance	Auto tracking 2500K to 9500K
Housing	Patented Heat Dissipating' Aluminum Housing
Power Source	12V DC ±0%
Power Consumption	110 mA (IR LED off) , 400 mA (IR LED on)
Operating Temperature	-10°C ~ 45°C
Operating Humidity	0% ~ 80% RH
Dimension	74mm(Ø) x 110mm(D)
Weight	500g
Country Of Origin	Taiwan

Dimensions

(UNIT: mm)

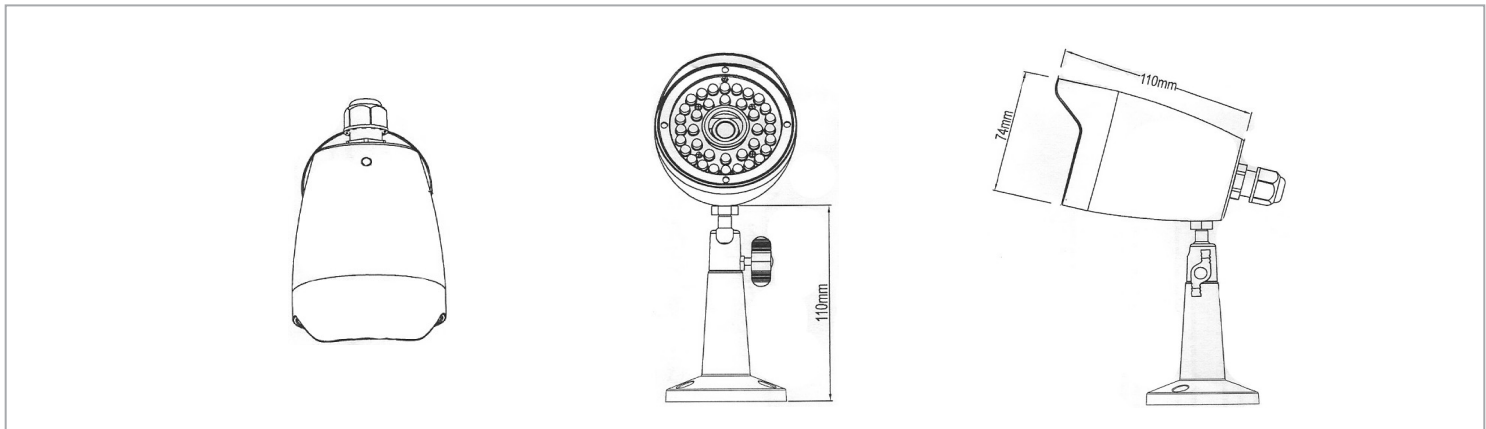

TANDÉR®